

DIY Modern Outdoor Chair

By Kourtnei Leigh www.houseonlongwoodlane.com

Step 1: Build arm base

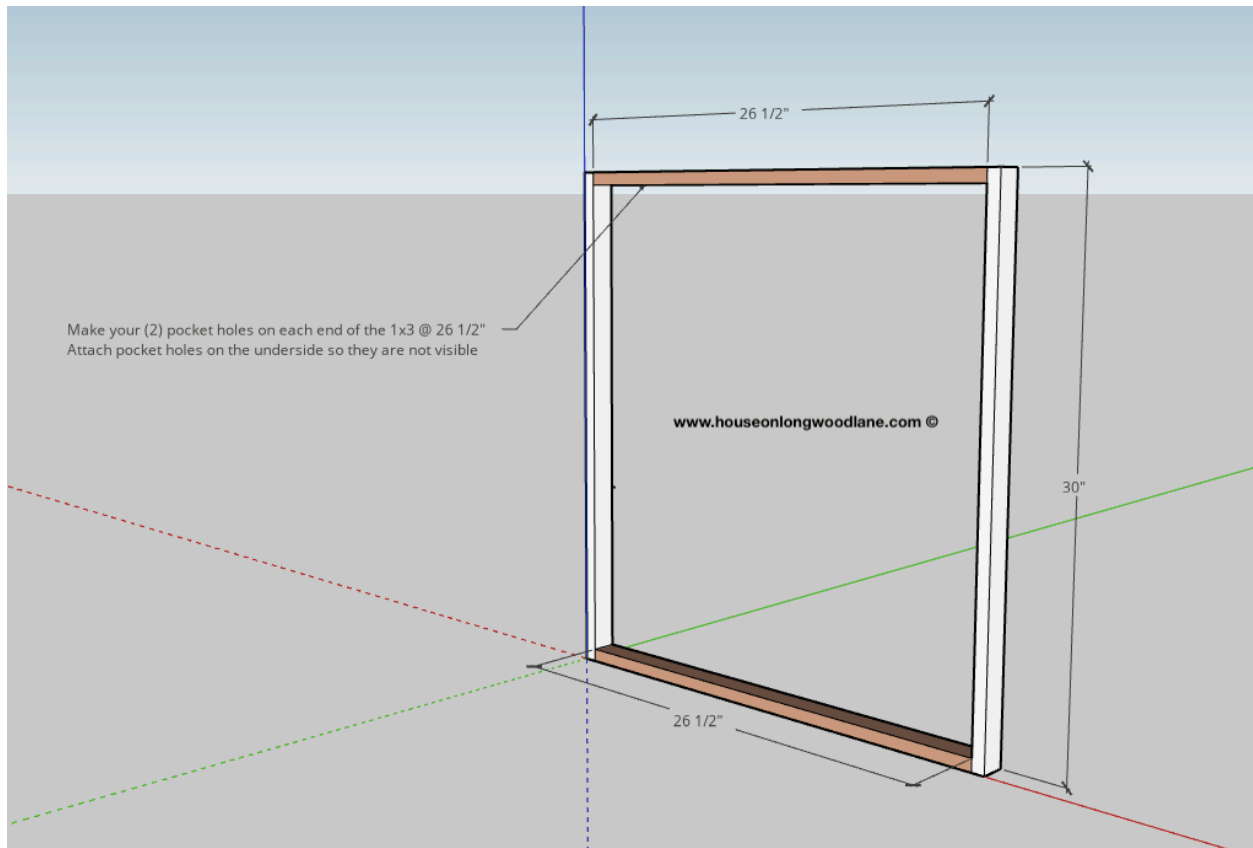

Step 1 Directions:

Before you start making cuts and assembling your chairs, remove the stickers off the wood before assembling. Learn from my mistake! I didn't remove one sticker and I wasn't able to stain the area due to the sticker not being able to removed.

Cut your arm base pieces using a miter saw and the 1x3x8 select pine boards. By cutting all of these pieces at once you can also make all the pocket holes for the arm bases as well! Cut 4 pieces at 26 1/2" and 4 pieces at 30".

Make your pocket holes using a Kregjig! I use the the Kregjig K4 and absolutely love it. Set your drill guide to 3/4" thickness and a screw length of 1 1/4". The pocket holes will ONLY go into the 26 1/2" boards.

Step 2: Attach arm base seat mount

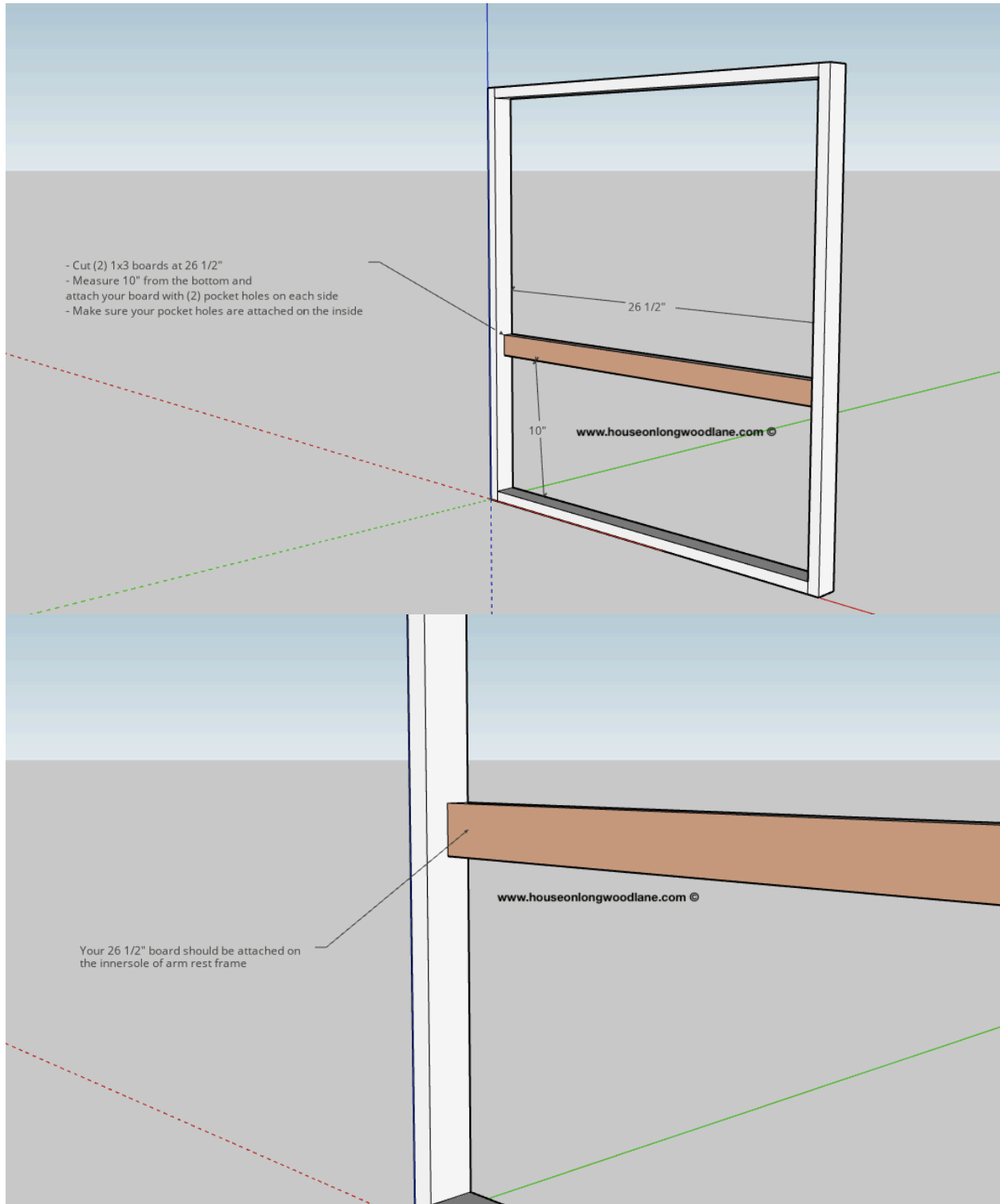

Step 2 Directions:

Cut 2 more 26 1/2" boards from the 1x3x8 for the center base mount. Measure 10" from the bottom of the 30" board and attach the 26 1/2" board with pocket holes facing inward.

Attach the 26 1/2" board to the innermost side of the arm rest frame. You may want to use some scrap pieces to brace the piece while you attach.

Step 3: Attach seat frame

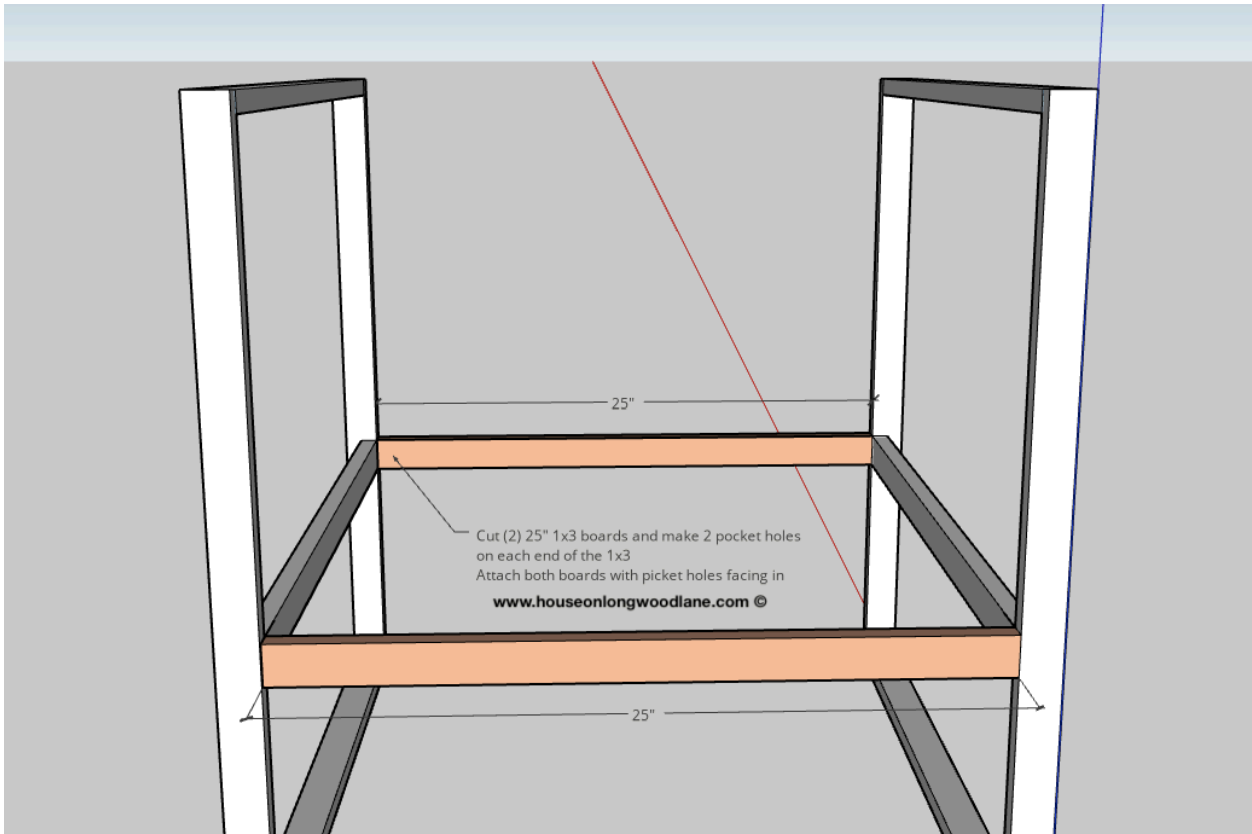

Step 3 Directions:

Cut a 1x3x8 @ 25" for both the front and back of the chair to form the seat frame. Make 2 pocket holes on each end and face pocket holes inward to hide when attaching.

Step 4: Attach 2x2 slat supports

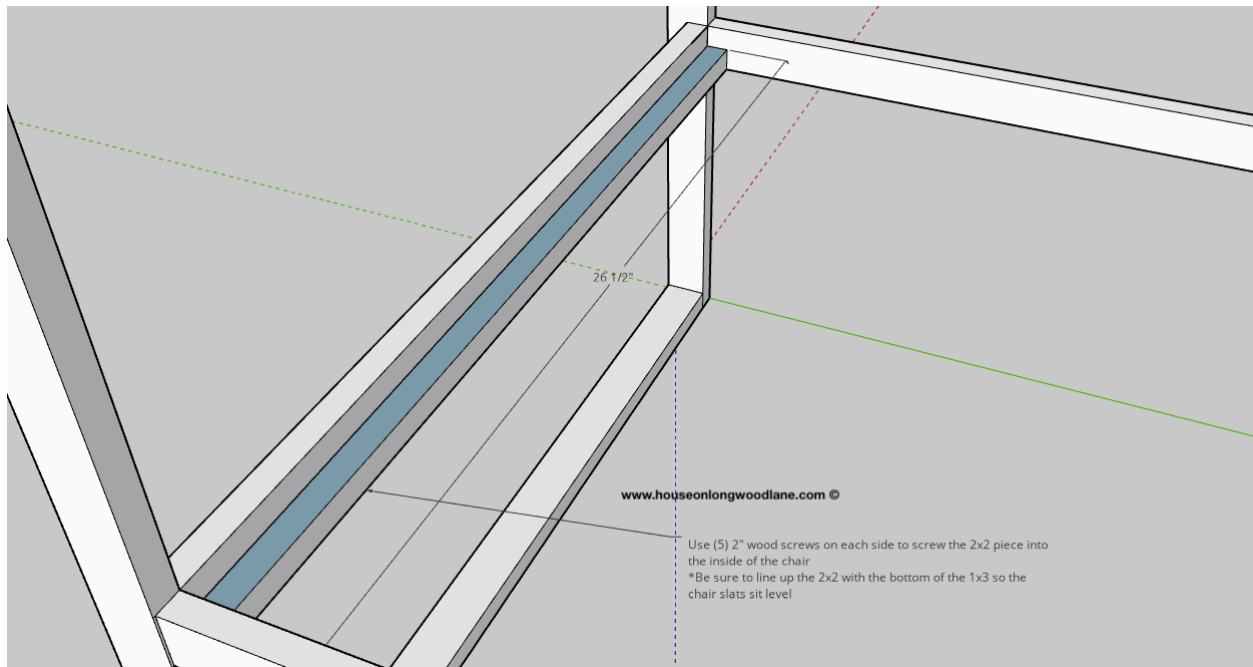

Step 4 Directions:

Cut a 2x2x8 @ 26 1/2", you may need to cut to fit. One chair I made had one side at 26 5/8" and the other at 26 1/2". This will be a snug fit and you may need a hammer or mallet to push into place. The 2x2 should be lined up with the bottom of the 1x3. Attach the 2x2 with (5) 2" wood screws!

Step 5: Attach seat slats

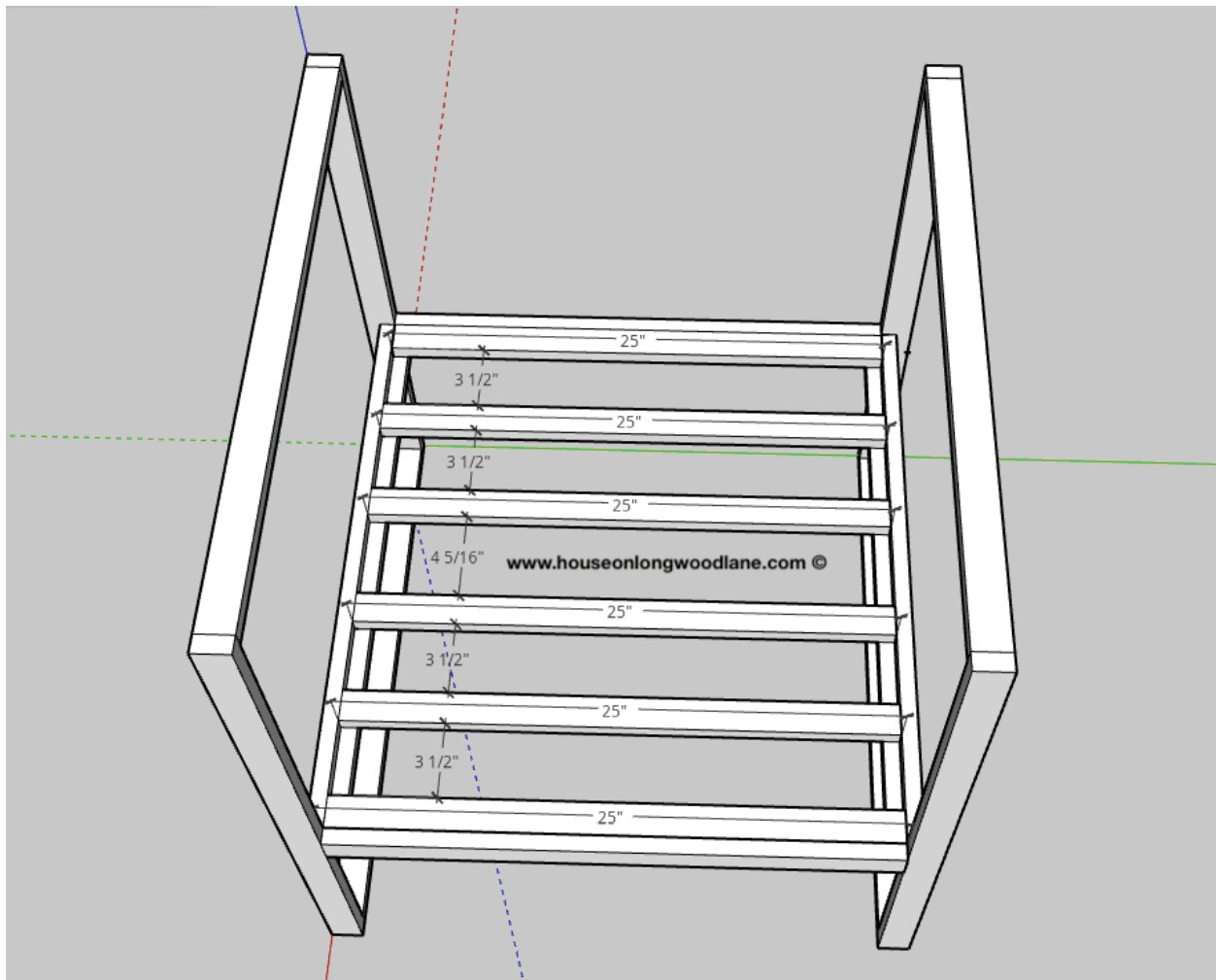

Step 5 Directions:

Attach the 6 - 1x2 seat slats at 25", again, measure to fit if needed! Use wood glue and 3/4" brad nails for each slat. Evenly space out the slats at about 3 1/2" apart, the back and front slats will fit snug against the 1x3 seat frame.

Step 6: Attach back slats

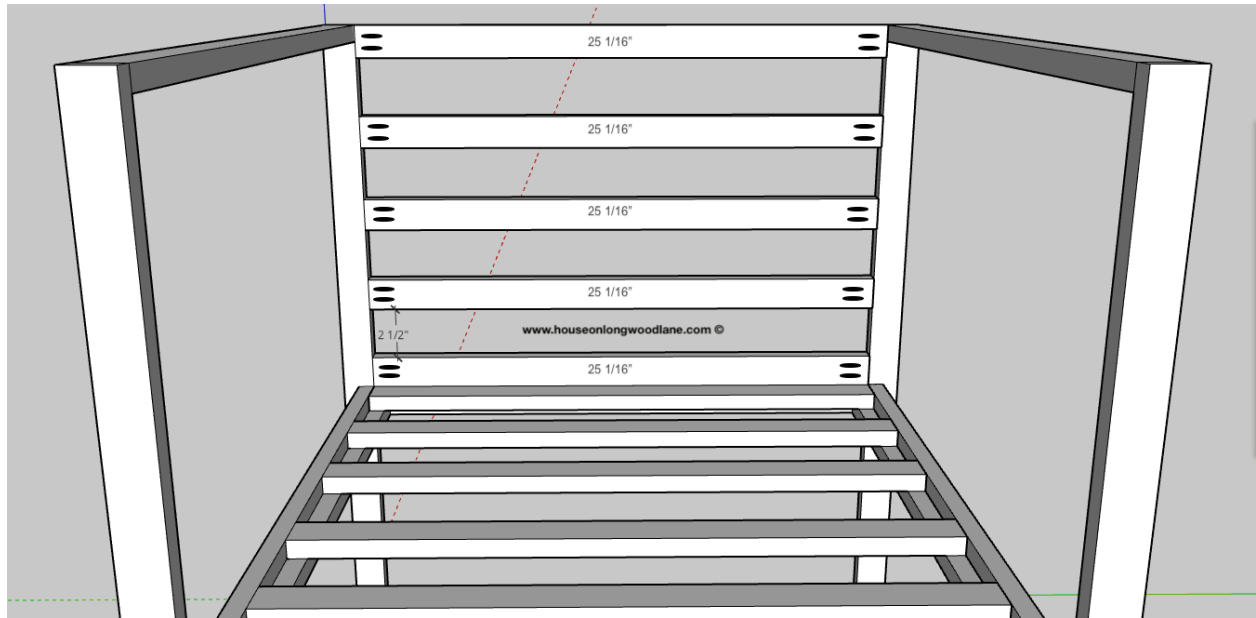

Step 6 Directions:

Attach the back slats with 1x3x8 @ 25 1/16". Each slat should have 2 pocket holes on each end attached with the pocket holes on the inside.

Step 7: Finished product

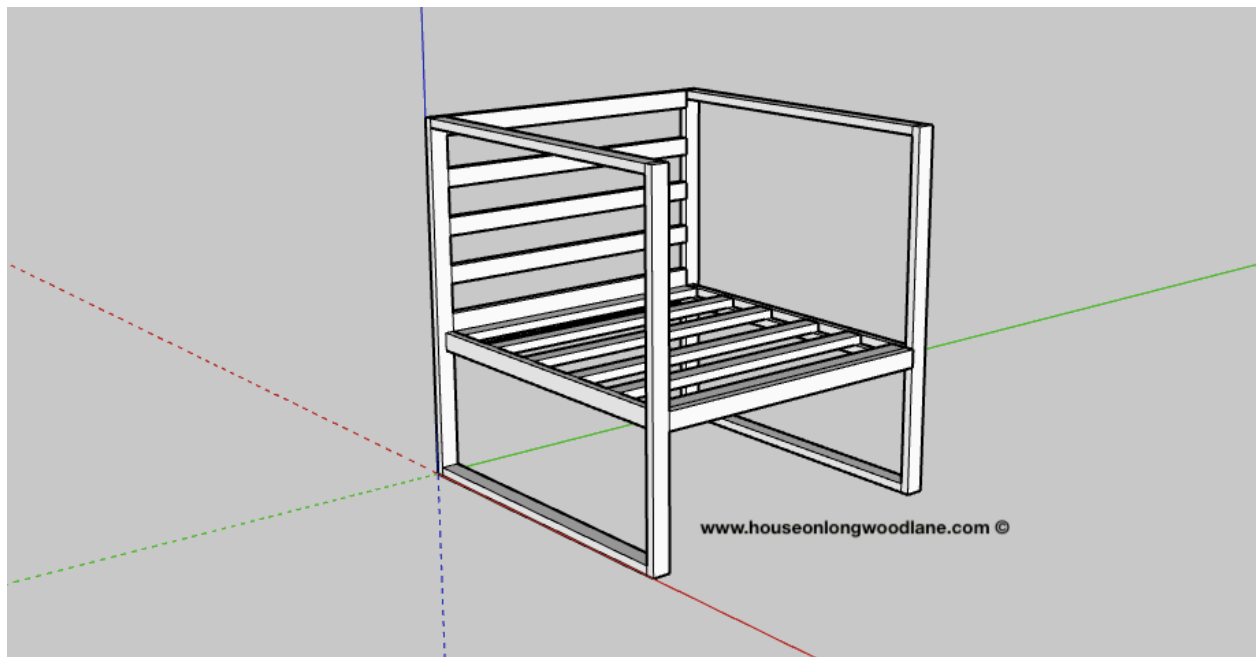

Step 7 Directions:

Now that the chairs are finished it's time to stain them! I used a new stain Varathane came out with this year called Flagstone available at Home Depot. Before staining sand with 180G and 220G sand paper. For a more in-depth tutorial on staining check out this post here!

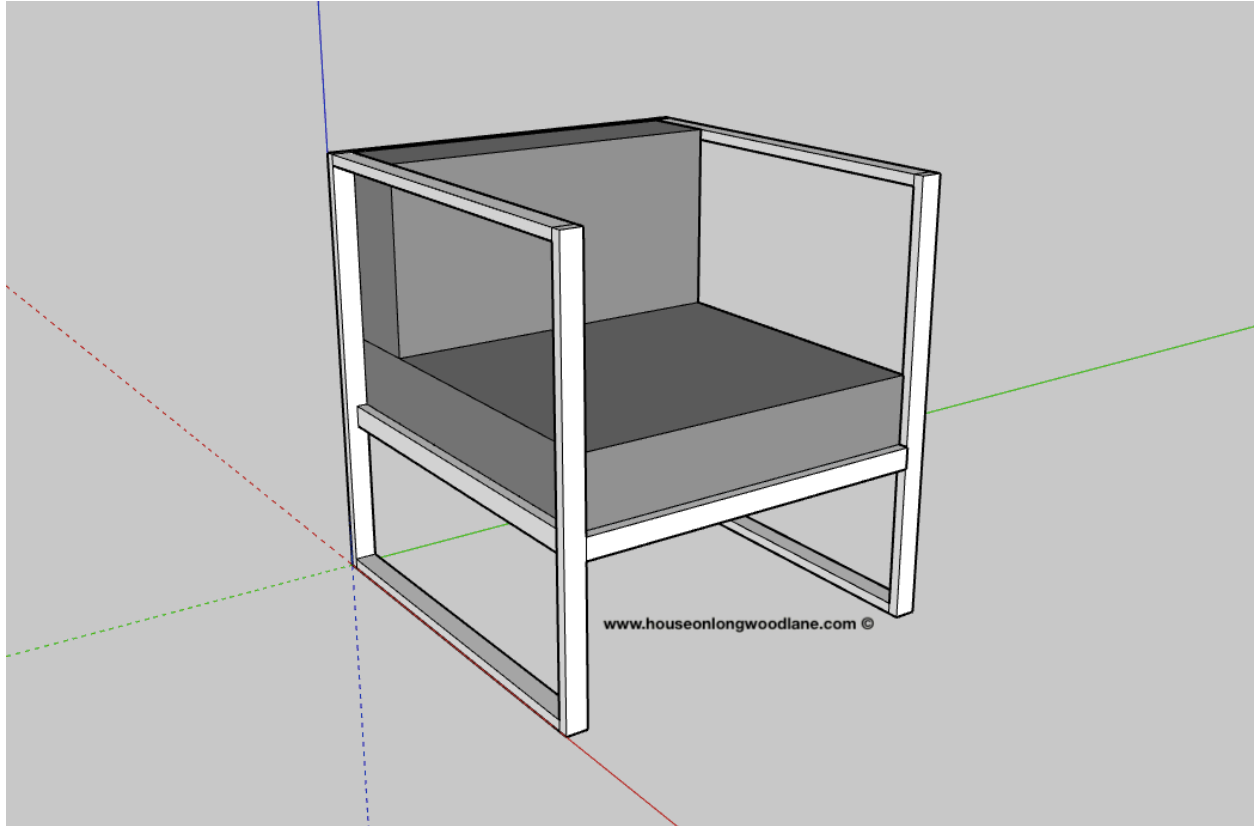

CUT LIST :

- 2 - 2x2x8 @ 26 1/2"
- 1 - 1x3x6 @ 25" (there will be extras)
- 6 - 1x3x8 @ 26 1/2"
- 4 - 1x3x8 @ 25 1/16"
- 1 - 1x3x8 @ 25"
- 4 - 1x3x8 @ 30"
- 6 - 1x2x8 @ 25"***If you are making 2 chairs you will not need an additional 1x3x6 for the second chair.

SKILL LEVEL :

Beginner/Intermediate

PROJECT COST:

\$72 - \$136